

preliminary

drawn by

bom

checked by

cw

lsw job number

08025

LEAVITT RESIDENCE

issue date

revisions

ANY REPRODUCTION AND/OR MODIFICATION
IN ANY FORM OF THIS DOCUMENT IS
PROHIBITED WITHOUT THE WRITTEN
PERMISSION OF lsw ARCHITECTS, PC

INTERIOR ELEVATIONS

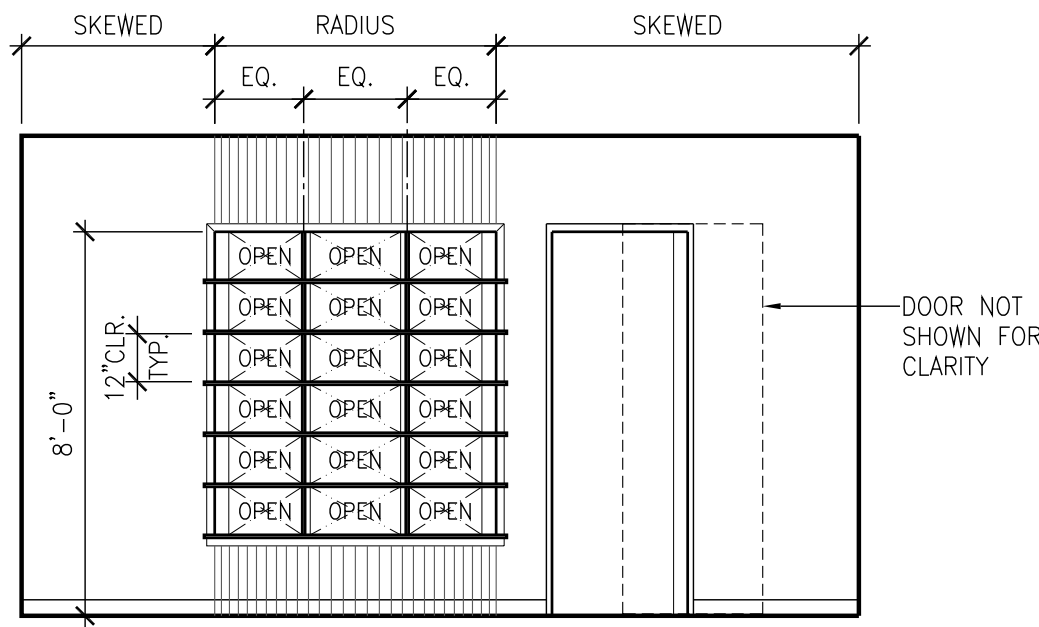

5 ENTRY / LIVING AREA

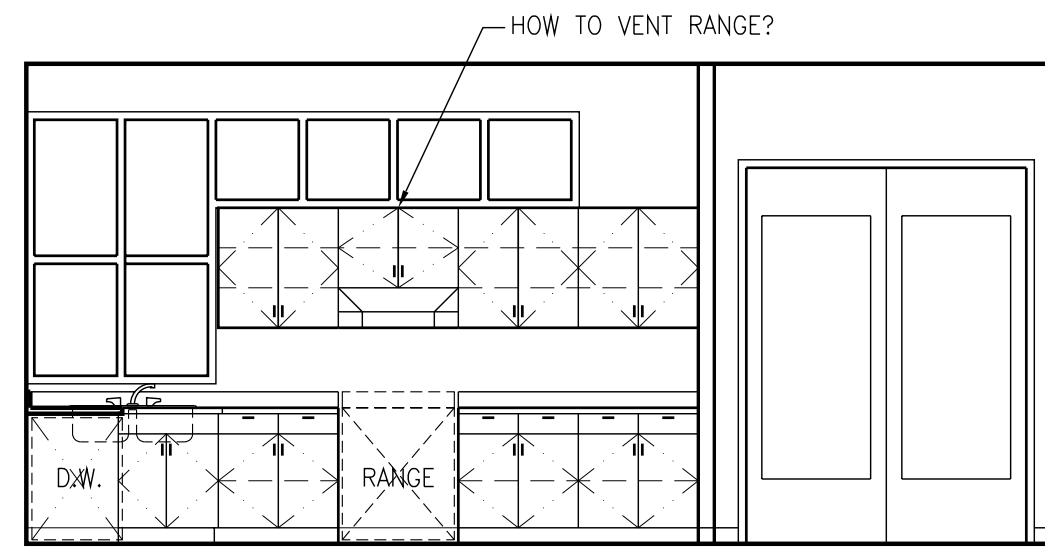

4 KITCHEN

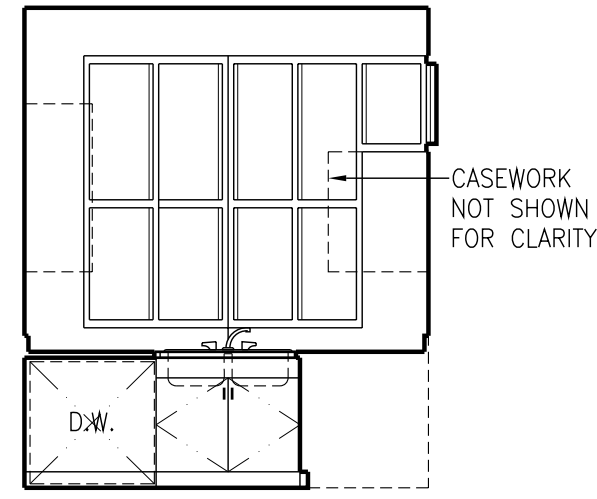

3 KITCHEN

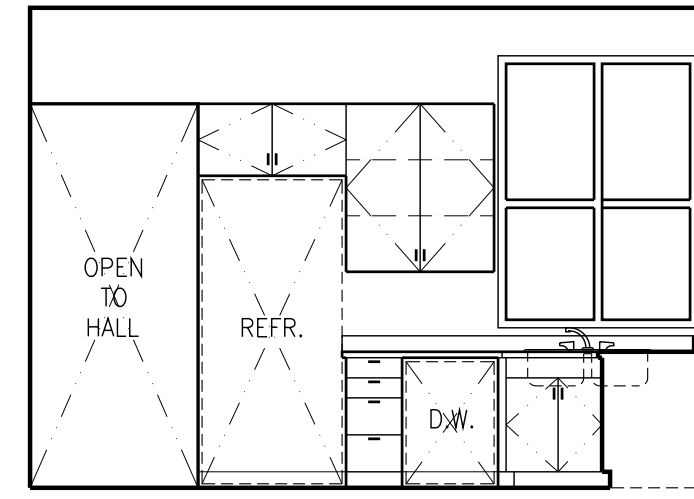

2 KITCHEN

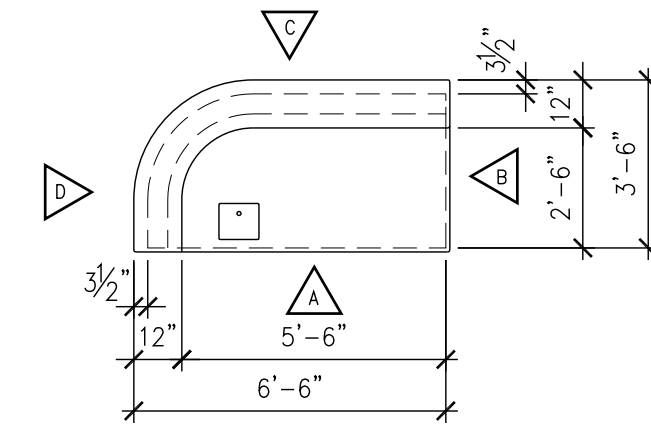

1 KITCHEN ISLAND

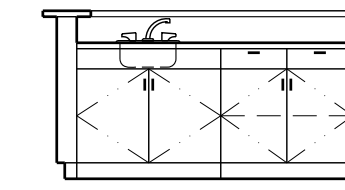

A

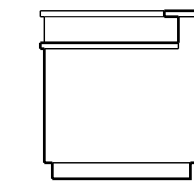

B

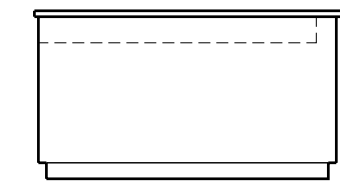

C

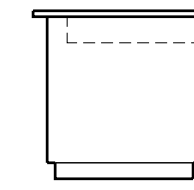

D

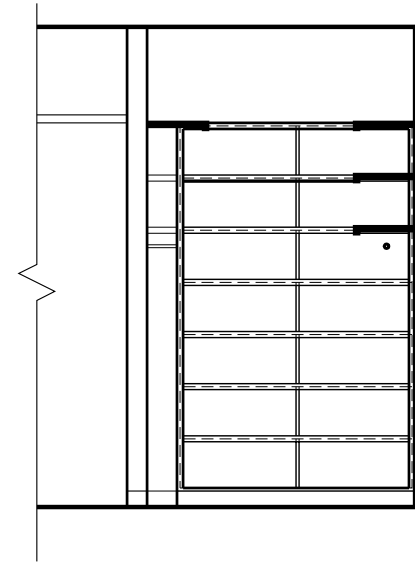

11 WALK-IN CLOSET

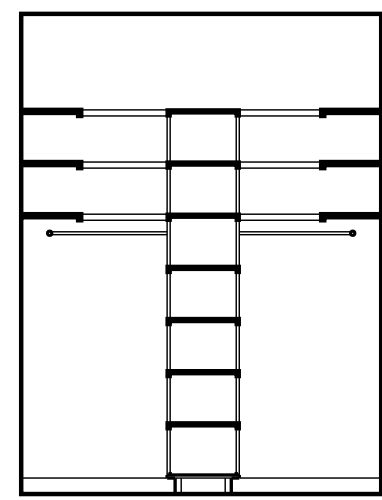

10 WALK-IN CLOSET

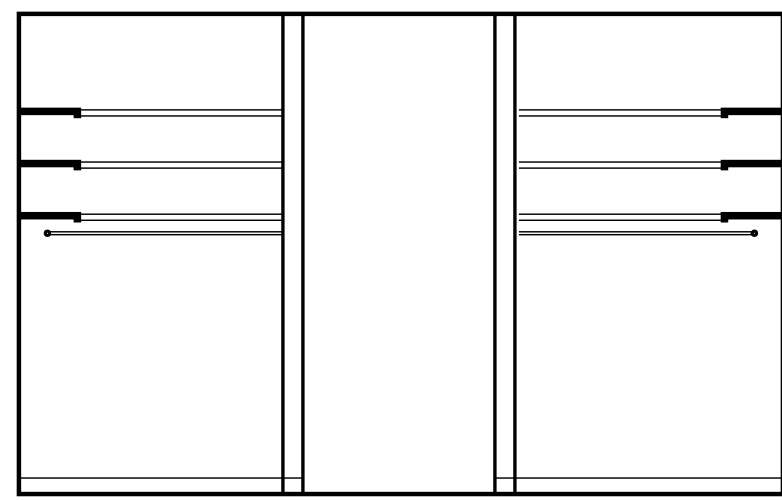

9 WALK-IN CLOSET

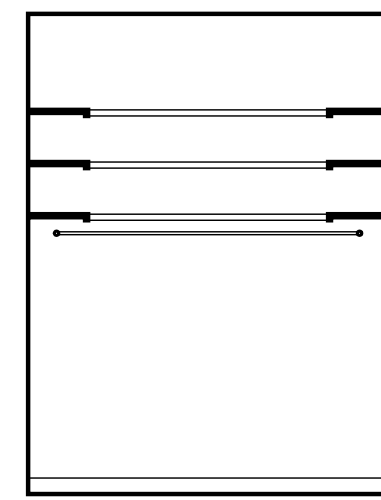

8 WALK-IN CLOSET

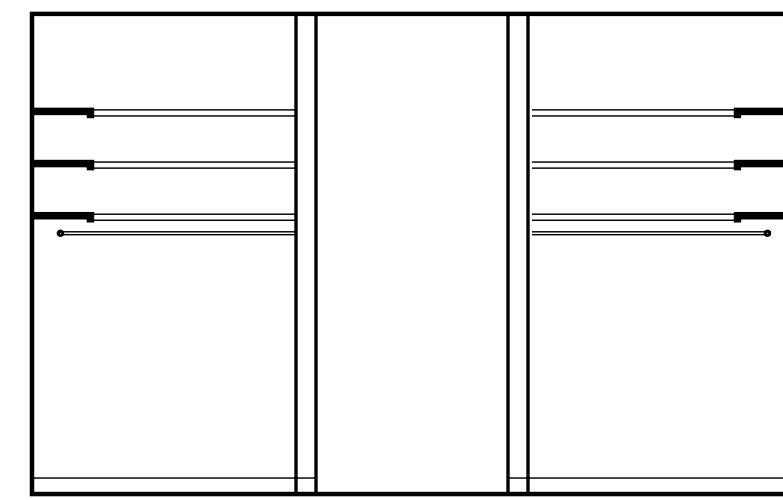

7 WALK-IN CLOSET

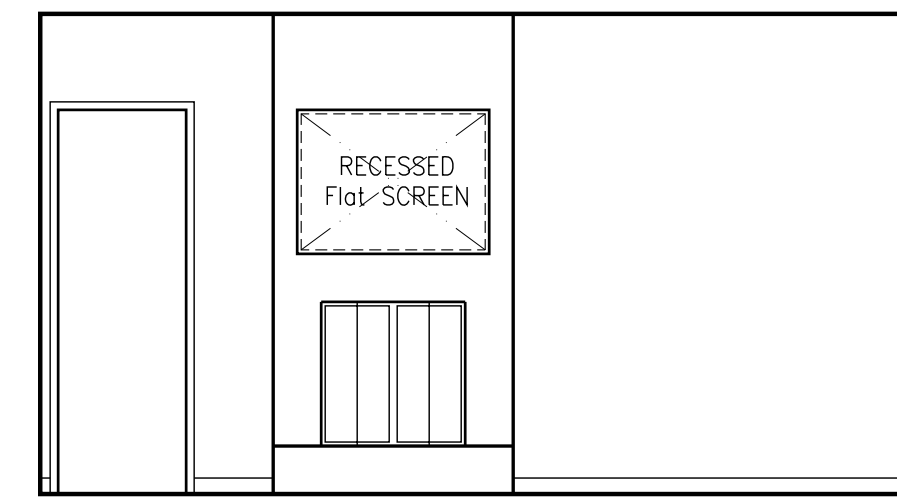

6 LIVING AREA

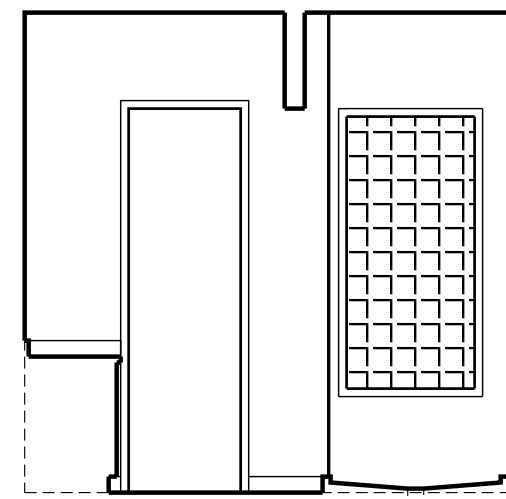

13 MASTER BATH ROOM/SHOWER

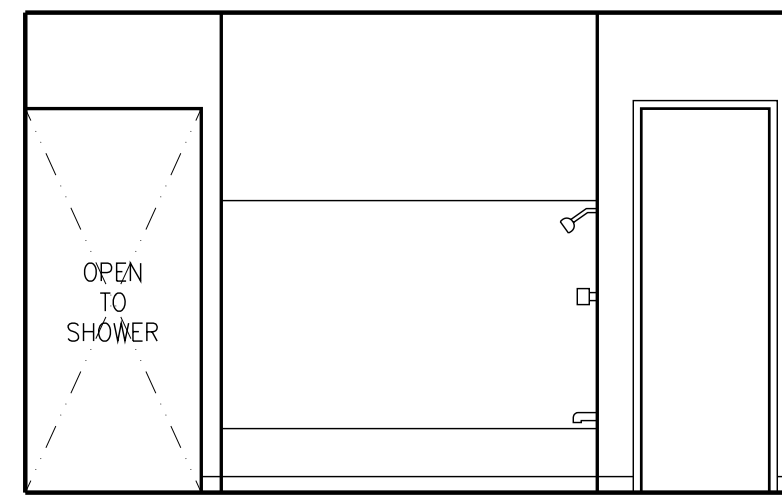

14 MASTER BATH ROOM

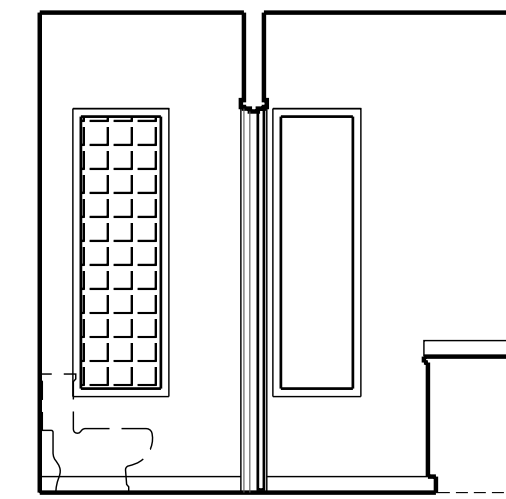

13 TOILET/MASTER BATH ROOM

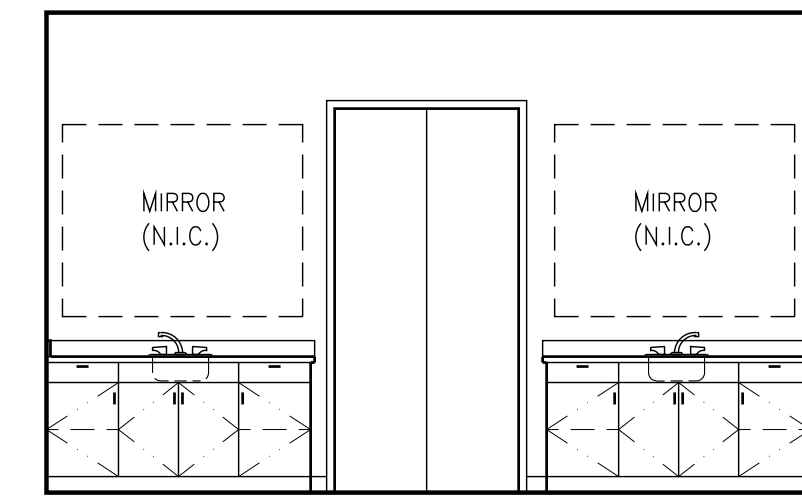

12 MASTER BATH ROOM

For Information Only
Not for Construction